

Fitting Guide and General Instructions

Surf Hardware International - HQ
P.O. Box 423, Newport Beach
NSW 2106 AUSTRALIA
Ph: 61 2 9997 4744
Fax: 61 2 9999 1537

Surf Hardware International - USA
4905 Morena Blvd #1306
92117 San Diego CALIFORNIA
Ph: 1 858 490 4353
Fax: 1 858 490 4350

Surf Hardware International - JAPAN
2-105-1 Ohno-Cho Ichikawa-Shi
Chiba-Ken 272 JAPAN
Ph: 81 473 380 971
Fax: 81 473 380 978

Surf Hardware International - HAWAII
94-356 Ukee Street, Unit B
96797 Waipahu HAWAII
Ph: 1 808 676 3027
Fax: 1 808 676 5440

Surf Hardware International - EUROPE
39 Rue de Sabotiers Zone Artisanale
40150 Soorts, Hossegor FRANCE
Ph: 3 35 5870 0040
Fax: 3 35 5870 0049

INDEX

Instructions for Shapers	2
Instructions for Glasser and Fin Installer	3
Resin Information	14
Instructions for Sanding	16
Fitting Fins	17
Fin Control Plug Repair	18
Installation Tools	20

INSTRUCTIONS FOR SHAPERS

1) Place pencil dot at front and rear of all 3 fins. The dots at the rear must reflect the exact point where the shaper wants the trailing edge of the fin to be.

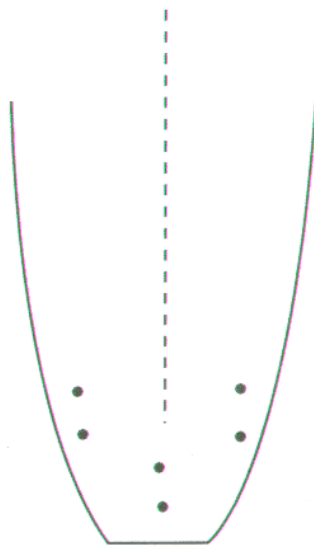
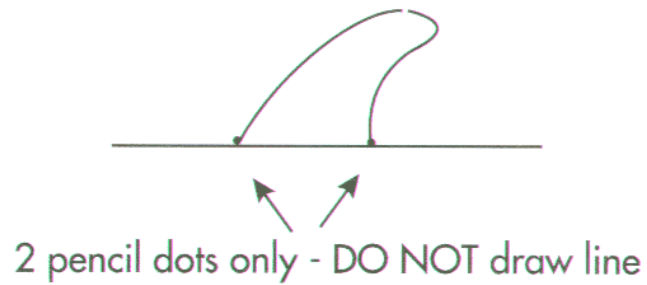

INSTRUCTIONS FOR GLASSER AND FIN INSTALLER

1) When glassing the underside of a surfboard add two extra patches of glass (approx. 150mm x 75mm , oval shape) around fin area to increase the strength. The deck of the surfboard should also have a minimum of two layers of glass over the fin area.

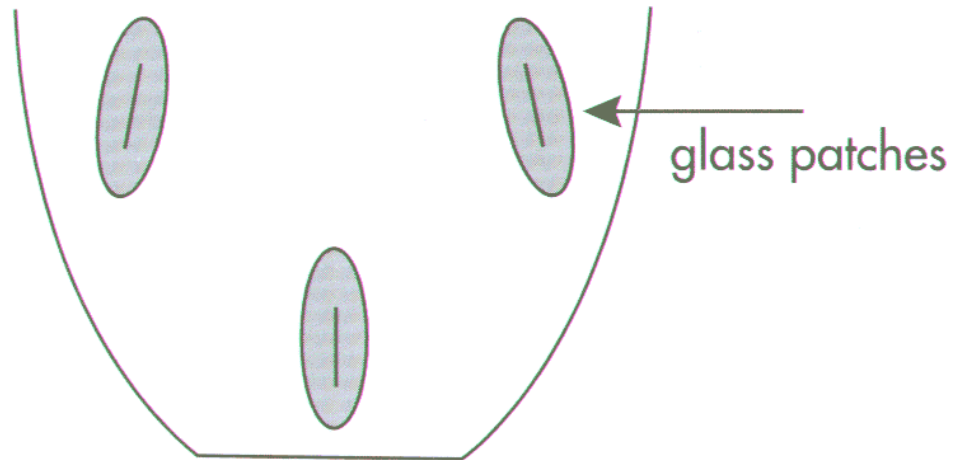

2) Apply fillercoat in normal manner

3) DO NOT SAND SURFBOARD . (It is possible to fit FCS plugs after sanding but to obtain a better finish please fit plugs before sanding)

NB: DO NOT fit leash plug until AFTER the FCS plugs have been installed. This is a precautionary measure to ensure the leash plug doesn't interfere with the FCS plug positioning.

4) Draw pencil lines through dots and extend cross lines. (see **DIAGRAM 1** overleaf)

DIAGRAM 1

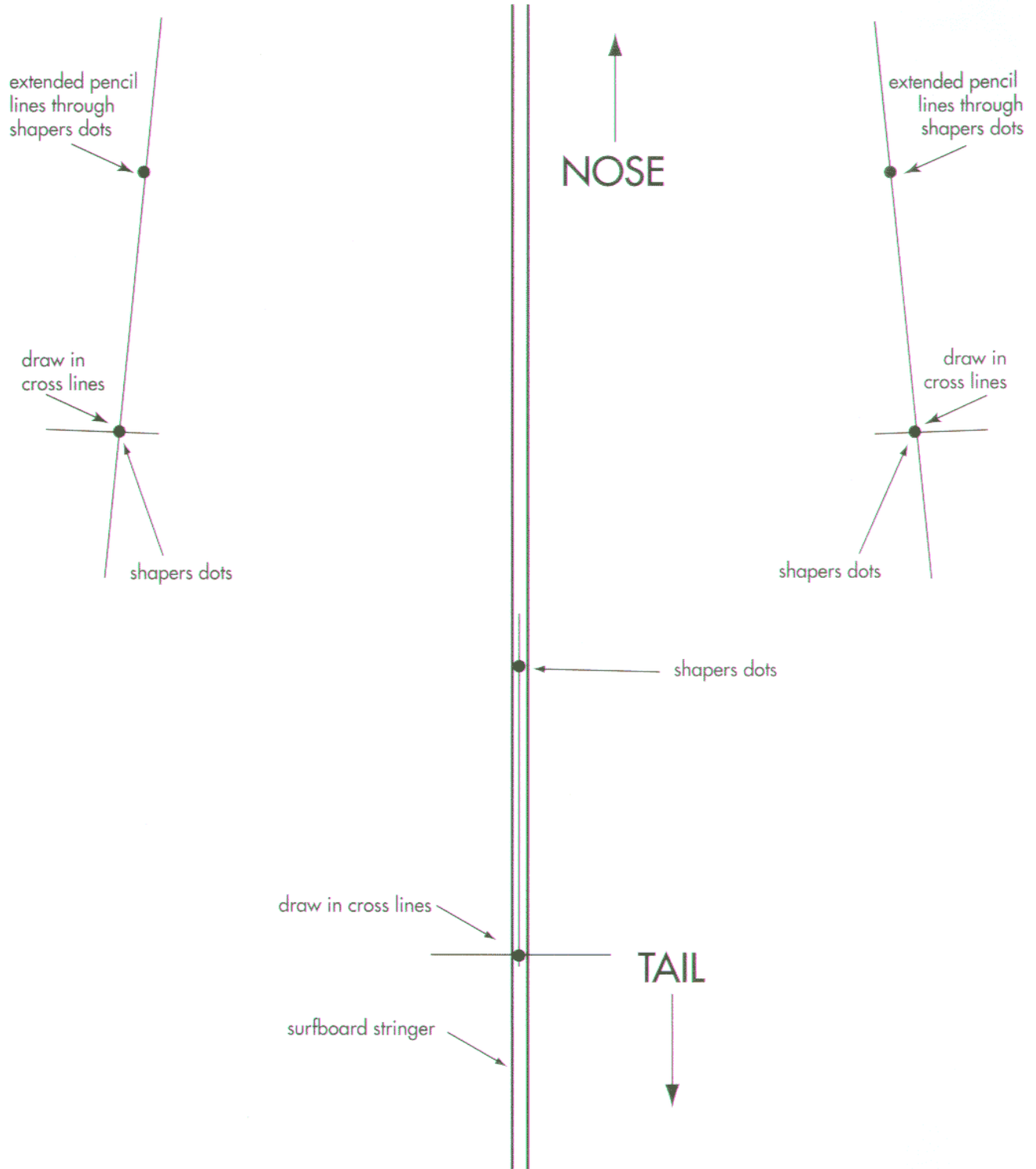

5) Using the FCS marking out template (tool **T-1**) mark out the centre and perimeter of the six holes as shown in **DIAGRAM 2 & 3**.

DIAGRAM 2

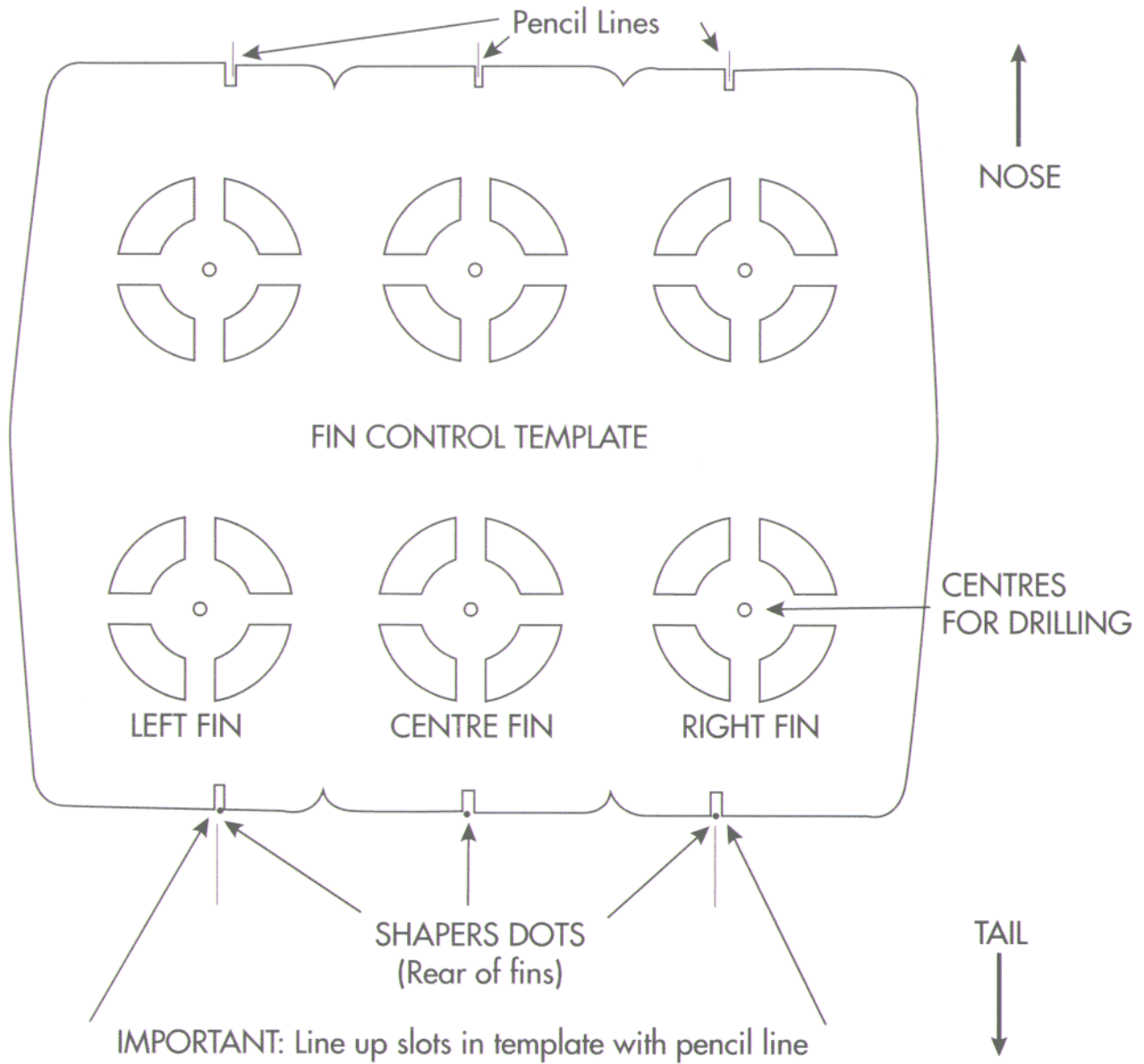
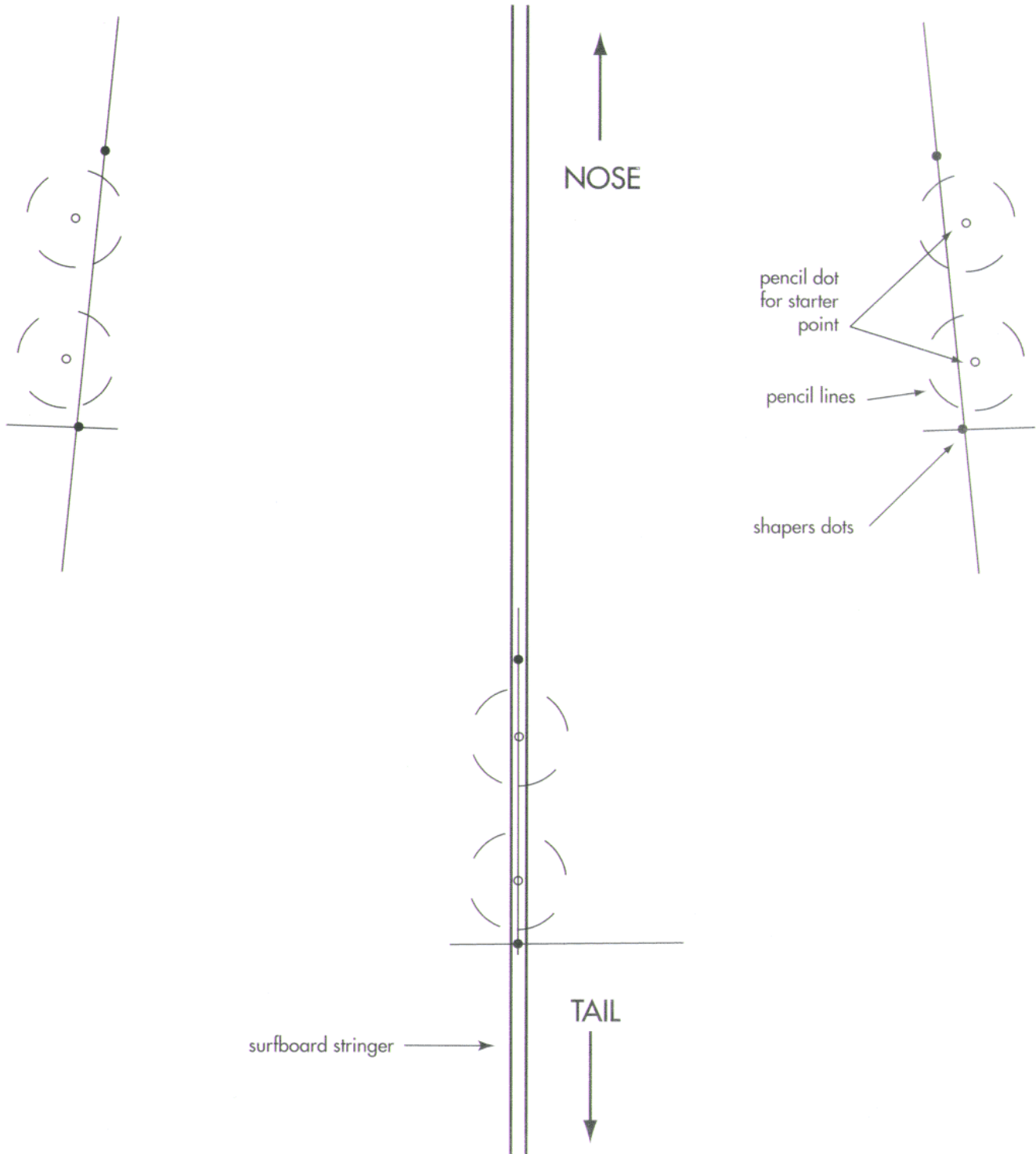

DIAGRAM 3



6) Using a centre punch (tool no. **T-2**) pierce down through the centre of the circles. These centre punch holes will be used as starting points / guide point for the holesaw.

7) Using the modified holesaw (tool no **T-3**) carefully drill 6 holes. The holesaw has a special guide, which only allows you to drill holes to the correct depth (2mm below depth of plug). If you have a thinner board retract the drill piece in the holesaw so it

does not pierce through the deck. Do this only after you have penetrated the glass.
IMPORTANT: Refer to **DIAGRAM 4** for correct holesaw setting.

DIAGRAM 4

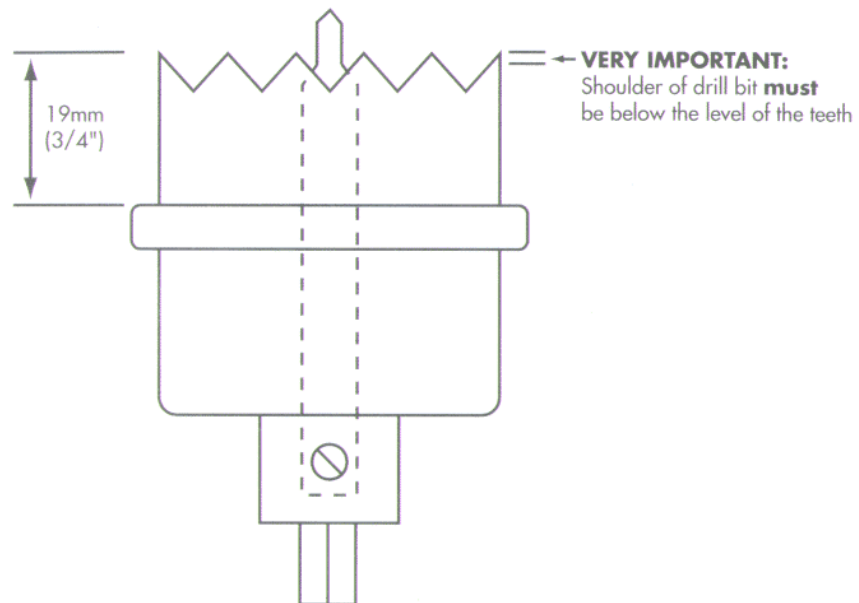

8) Remove fibreglass circles.

9) Place steel tube (from tool no. **T-4**) into holes as far as possible.

10) Using the borerbit (tool no. **T-5**), drill/bore out the centre of the six holes using the steel tube as a guide. The borer bit also has a guide which will stop it at the correct depth. (Please note the borer bit must be the same length as the steel tube)

11) Remove the steel borer bit and tube and turn board upside down and gently tape out excess residue.

12) Fit the H-Pattern Tool (tool no. **T-6**) to the drill and very carefully drill down slowly until the bit gently scrapes against the under side of the deck. Don't press too hard, as the H-Pattern tool will go through the deck. You can place your hand underneath the hole so you can feel the H-Pattern tool getting closer.

13) IMPORTANT: Remove the H-Pattern tool and clean holes out. Use the scribe tool (tool **T-7**) to scrape away residue foam at the bottom of the hole to expose the fibreglass deck. A circular shadow **MUST** be visible from the deck.

14) Optional -To increases the strength even more you can counter sink under the glass as shown below. (See **DIAGRAM 4B**)

DIAGRAM 4a

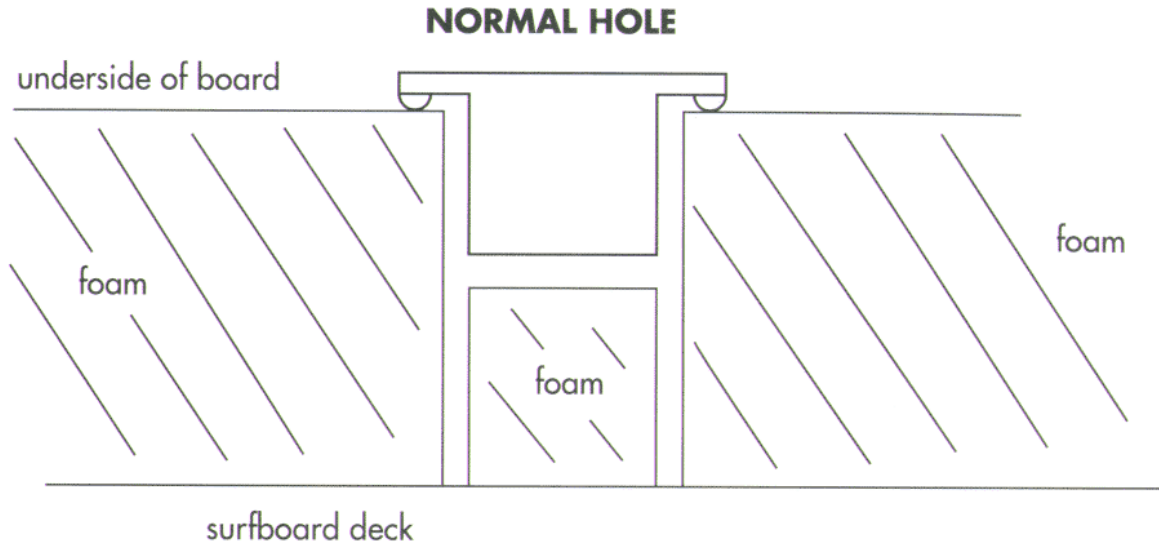
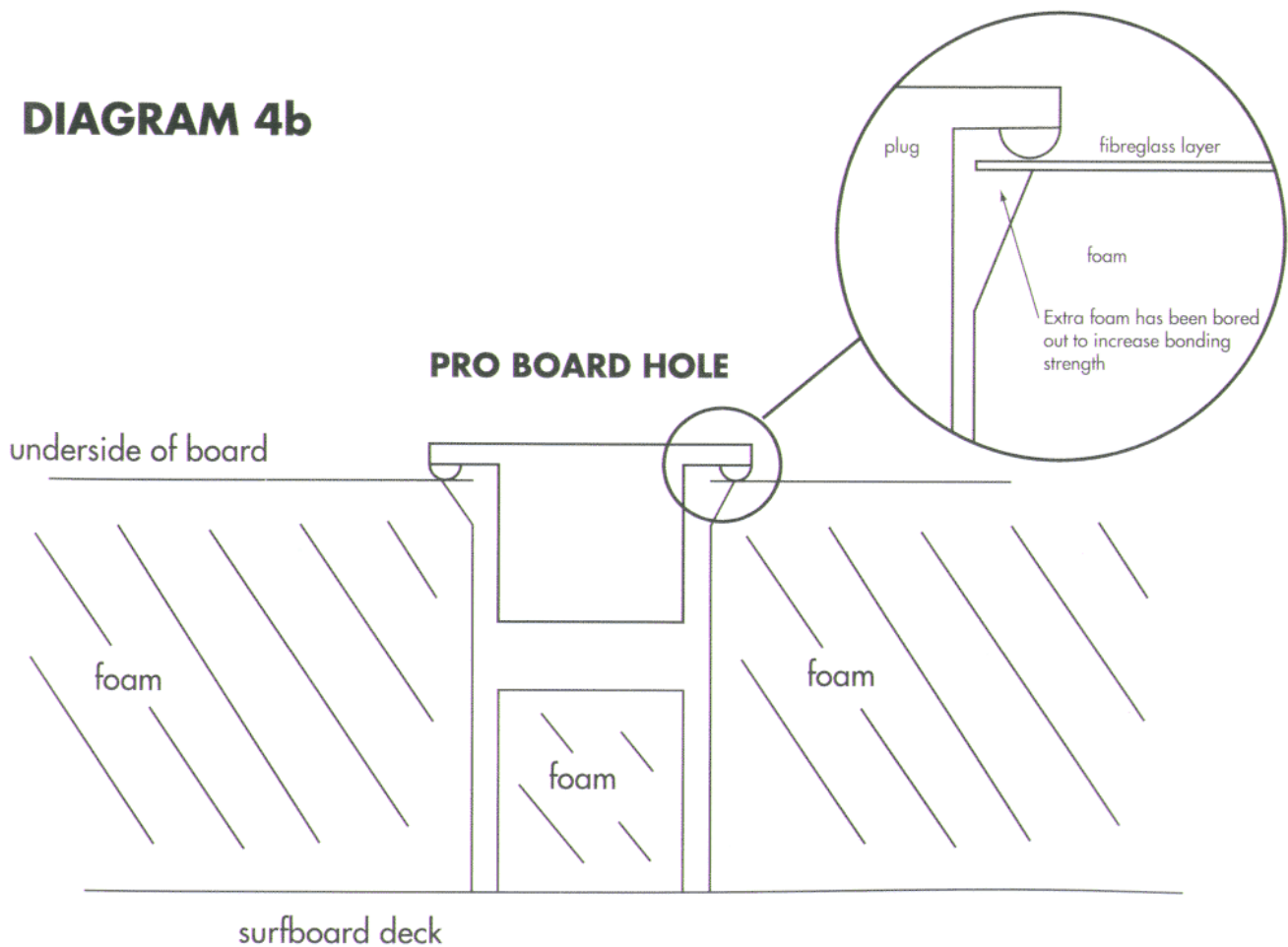
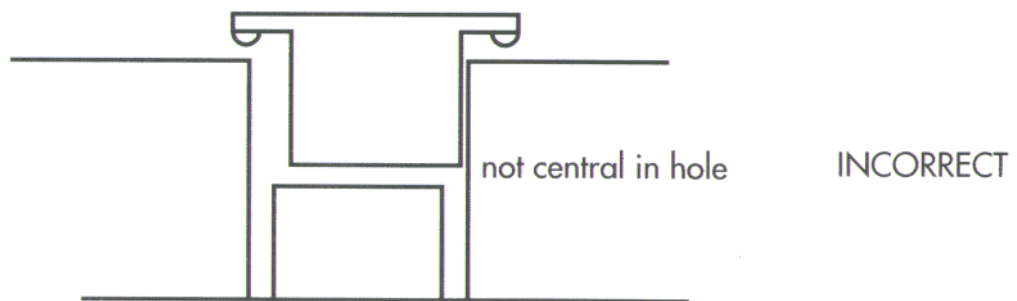
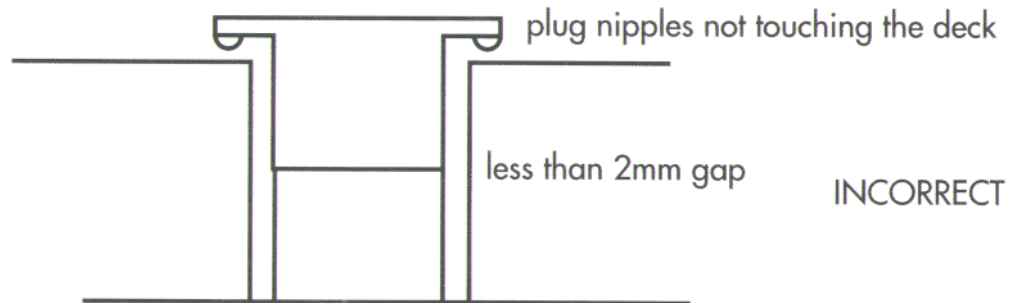
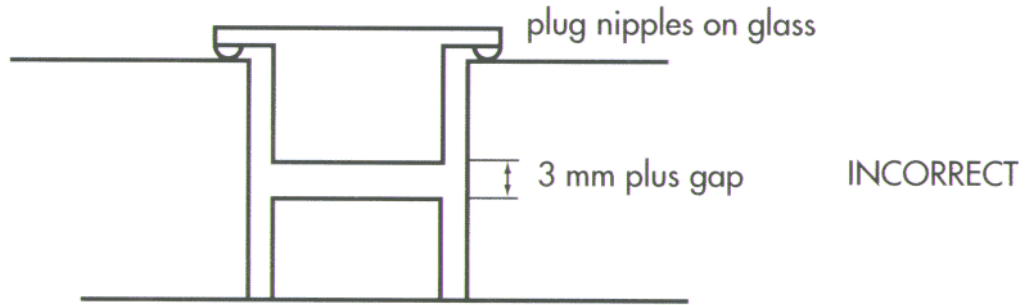
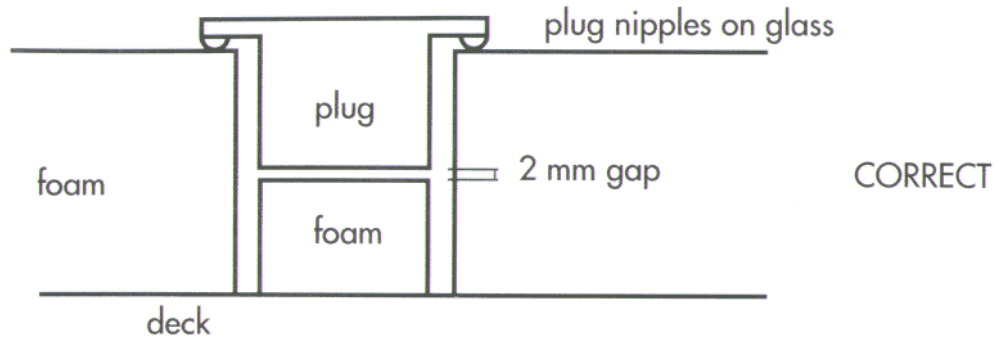

DIAGRAM 4b



15) Place plugs into holes to test that holes are deep enough. (See **DIAGRAM 5**)

DIAGRAM 5



16) Place Zig Zag Foam (see **DIAGRAM 6**) around holes to create dam effect.

DIAGRAM 6

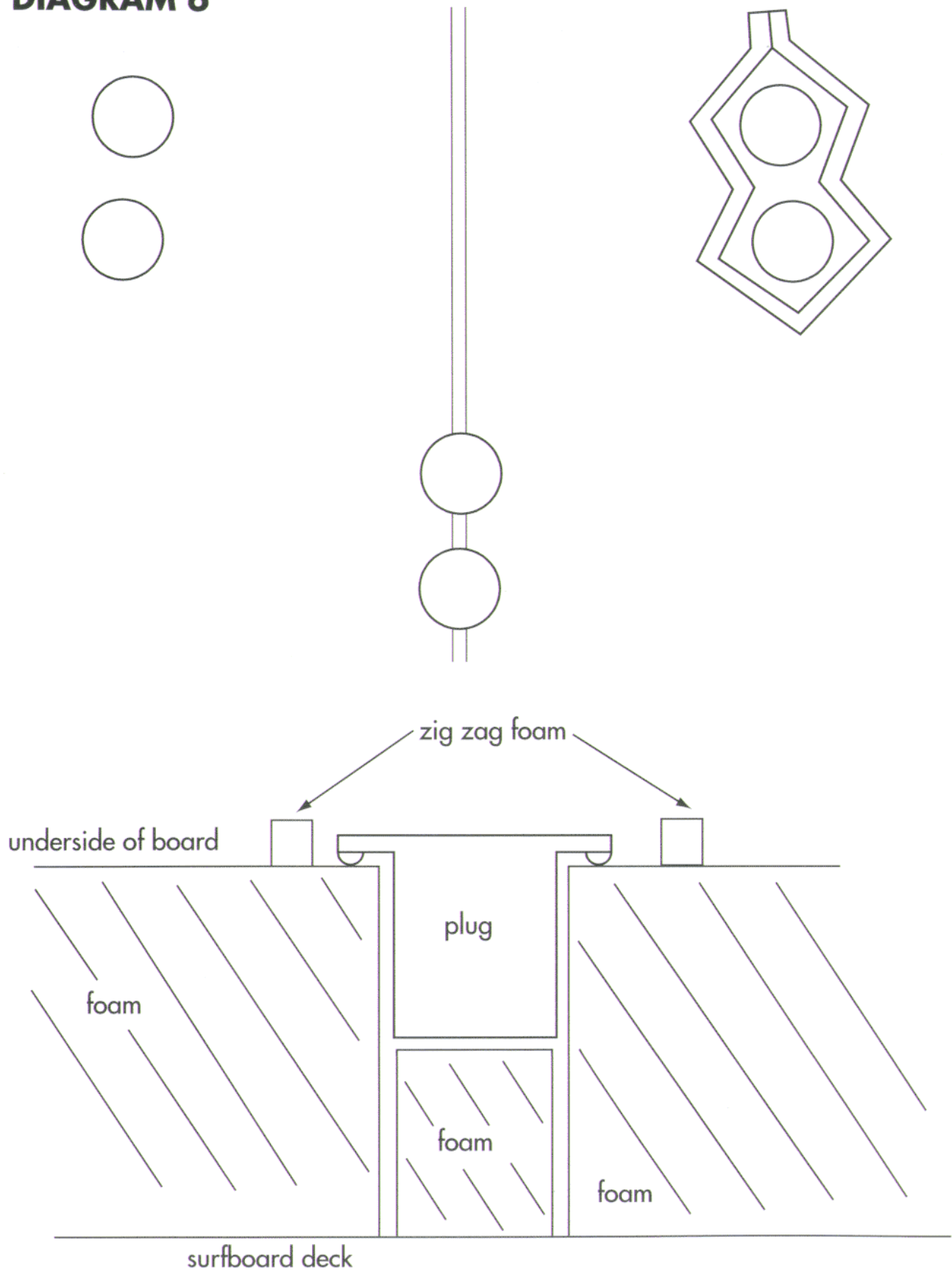

17) Place 6 plugs onto plastic dummy fin jigs (tools **T-8a** and **T-8b**) . Position on jigs as per **DIAGRAM 7**.

DIAGRAM 7

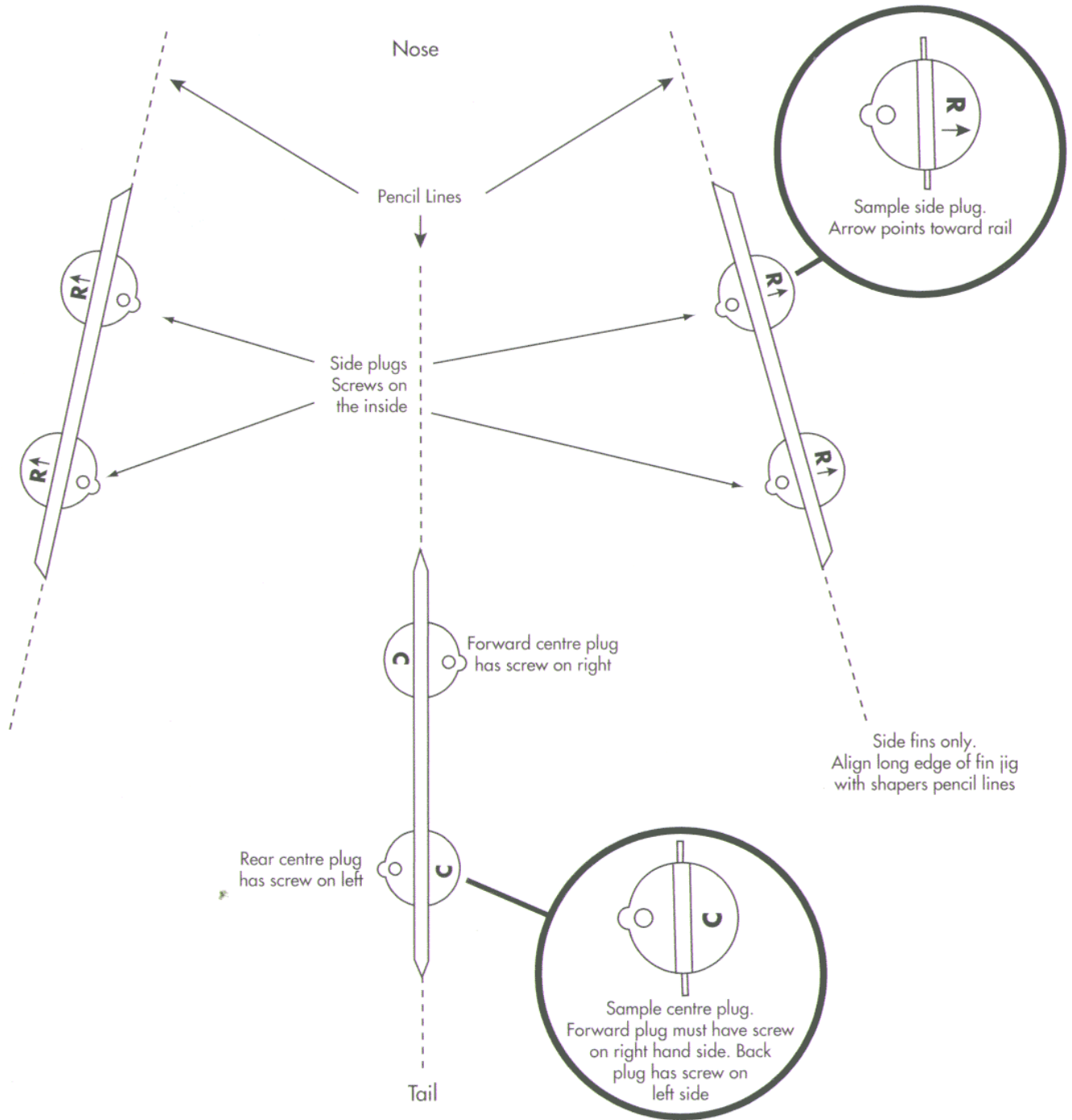

18) Using a cloth soaked with acetone, wipe the outside of the plugs only. Do not allow acetone into slot and do not soak plugs in acetone. Simply wipe the plugs. A black residue should be visible on the cloth after wiping. Another alternative is to rough the surface up with course sandpaper. Both these methods enable the resin to bond stronger. Do not handle plugs after treating.

19) Place plastic fin jigs into position and hold at correct angle with tape or putty. Refer to **DIAGRAM 8**. Note : plugs must sit flat on the surfboard.

DIAGRAM 8

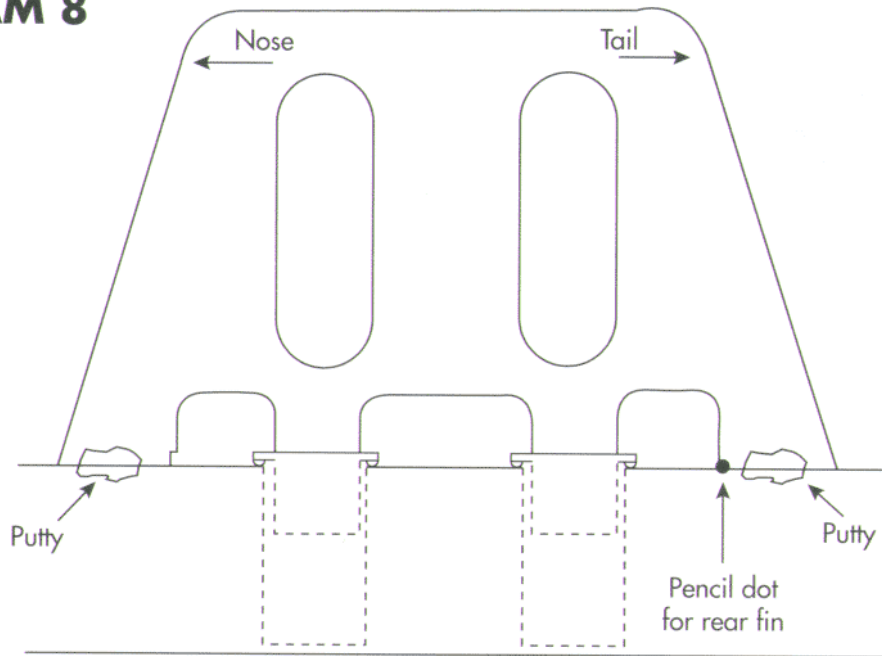

OR

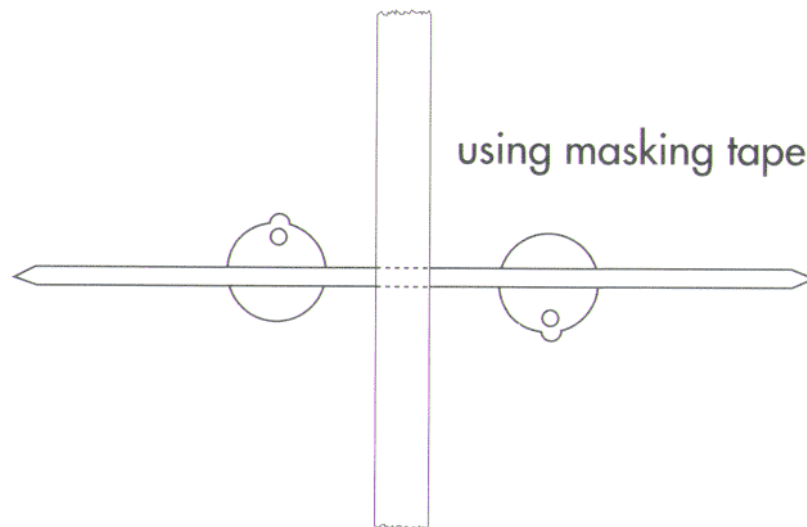

20) RESIN AROUND THE PLUGS - FCS has developed its own plug resin for the installation of its system (see next page). This has been designed to increase strength and speed up installation time. The new resin has a PVC bonding material, white pigment for colour, wax in styrene for ease of sanding and bubble release agent. The only item you need to add to the FCS Plug Resin is the hardener (1% - 2% depending on conditions). You can still use normal resin but it won't have the same properties as the new FCS plug resin.

If you are not using the FCS premixed resin, the correct formula is as follows for a 3 fin installation:

Resin - 100 mls

Fibreglass Powder - 15 mls

White Pigment

Catalyst - 1% - 2%

21) Place two wet sponges / rags under each side fin area to prevent possible overheating and discolouration. This generally should not be necessary if using FCS resin.

22) Pour resin into a squeeze bottle (tool no. **T-10**) and slowly pour into the holes from one side so that the air is pushed out the other side. Fill to the top of the Zig Zag foam and pop any bubbles which may appear. Check the resin level every 10 minutes to ensure it hasn't soaked through or drained out.

23) Remove jigs once resin has gone cold and hard.

RESIN INFORMATION

CUSTOM FORMULATED PLUG RESIN FOR F.C.S. WITH EASY TO USE DISPENSING UNIT

After over 1 year of rigorous research and testing with some of Australian's largest surfboard manufacturers F.C.S. has introduced a new PREMIXED polyester resin specifically designed for the installation of F.C.S. plugs into surfboards. The only item you need to add is the catalyst.

The major features of this resin are:

- There is no need to add fibreglass powder.
- The resin is made from a new low exotherm formula greatly reducing the risk of overheating when installing the FCS system. This resin is approx. 30% cooler than standard resin on the market.
- A special P.V.C. bonding agent has been added to ensure maximum adhesion between plug and resin.
- A special air release agent has been added to reduce air bubbles and the possible need to back fill after sanding.
- Correct amount of pigment and wax in styrene added to ensure ease sanding and aesthetics.
- Available in either 20L pail or 10L tin. (200 and 100 installations respectively)

In conjunction with this the new Pre-Mix FCS Plug Resin, a unique mixing drum / dispenser has been developed to ensure the resin can be easily mixed and dispensed. This will save the installer enormous amounts of time and eliminates any chances of incorrect formulas and waste.

FCS Resin Mix

100mls of FCS plug resin

1%-2% catalyst depending on conditions

Traditional Resin Mix

100mls of resin

15 mls of special fibreglass powder

White pigment (not too much)

Hardener (1-2% depending upon conditions) The resin must be runny and set slowly.

Do not make a hot mix.

Mix thoroughly in mixing bowl

DIAGRAM 9

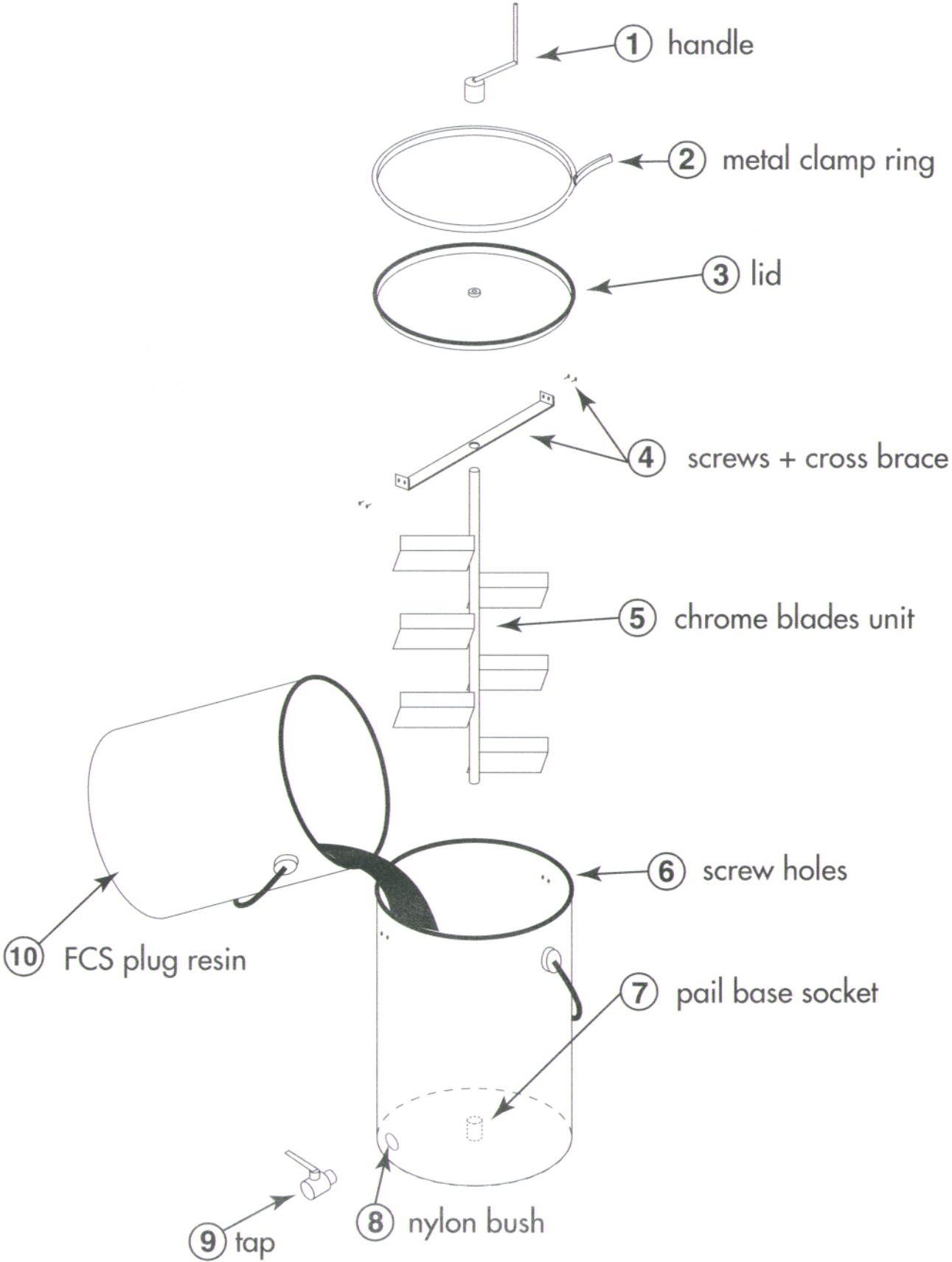

INSTRUCTIONS FOR SANDING

- 1) Wind grub screws down well below sanding level.
- 2) Don't over heat plugs when sanding.
- 3) Firstly use a coarse / heavy sanding disc to remove bulk of material. Avoid over heating by turning sanding machine on and off while sanding.
- 4) Sand surfboard in usual manner.
- 5) CLEAN OUT SCREWS OF ALL SANDING RESIDUE to eliminate key fitting problems. There must be no residue left in the screws or fin slots . Key must fit into screw hole to correct depth. (See **DIAGRAM 10**)

DIAGRAM 10

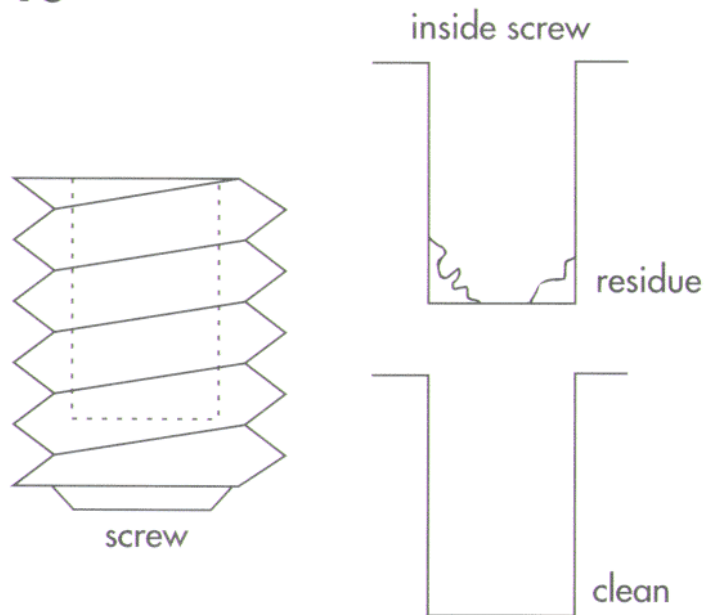

- 6) Deck sticker can be fitted to cover up circle shadows on deck.

FITTING FINS

- 1) Do not force fins into plugs.
- 2) Do not over tighten screws. Just nip tighten them.
- 3) If fins are stuck in at any stage, place a razor blade or knife underneath trailing edge and gently pull fin back. (See **DIAGRAM 11**) This will spread the load and eliminate piercing the glass.

DIAGRAM 11

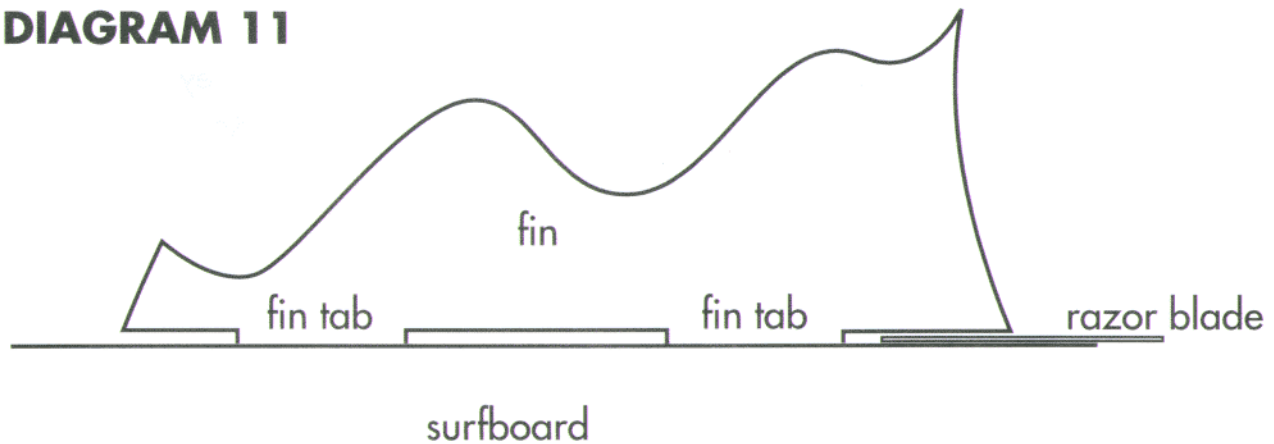

- 4) If screws are filled up with sanding residue (white material) use a spike or something sharp to break up and remove. If this material is not removed, you will have problems with the fitting of keys into the screw slot. (See **DIAGRAM 12**)

DIAGRAM 12

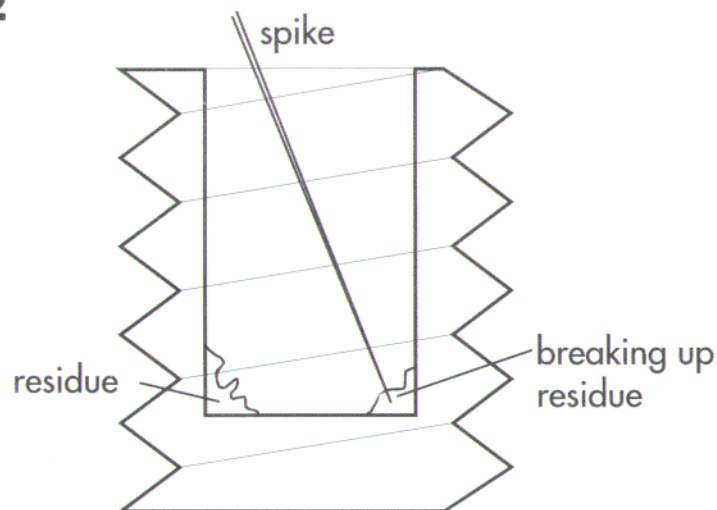

- 5) If screw is stripped, use over sized key to remove. (It may be easier to wind screw down through into the plug slot after first removing the fin.)

FIN CONTROL PLUG REPAIR

Genuine composite FCS fins are engineered to break off at the tabs under severe side impact. If a fin breaks off in the plugs, simply undo /unwind grub screws, turn board upside down and gently tap broken fin tabs out. If the tabs are stuck due to salt build up you can use a pair of pliers or unwind screw completely out and use the key as a lever to push the tab out. (See **DIAGRAM 13**)

DIAGRAM 13

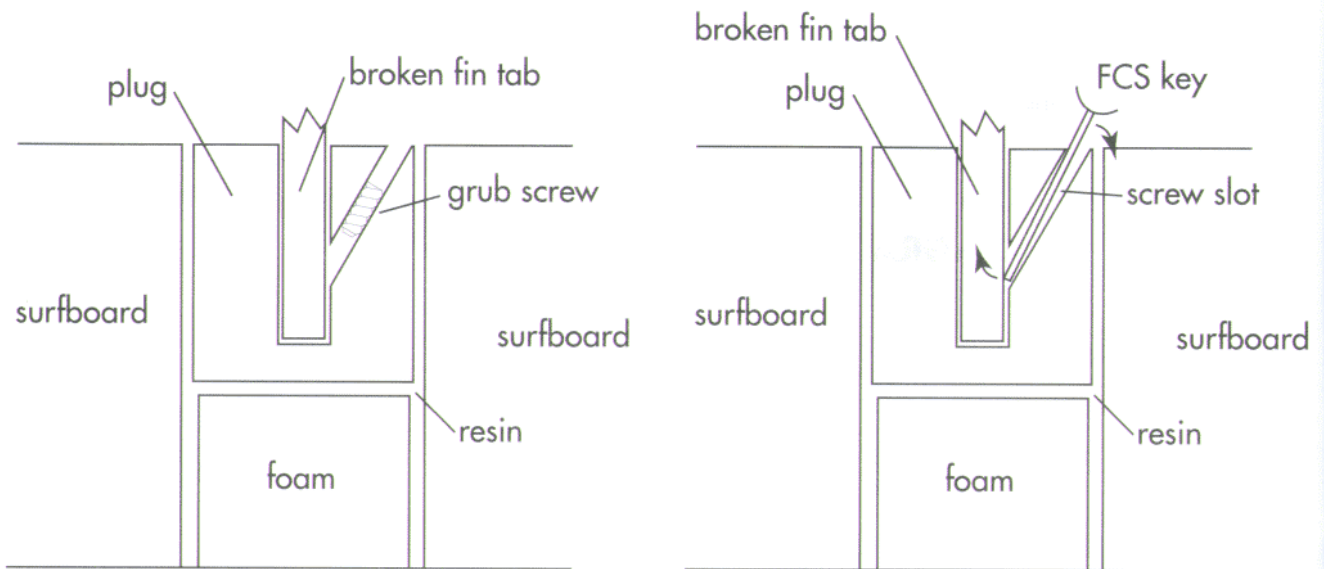

If the plug is damaged in some way it will have to be replaced by the following method.

- 1) Using a hot melt glue gun stick down the repair drilling jig (tool no **T-11**) into position over damaged plug.
- 2) After removing drill bit from centre of holesaw, drill out damaged plug.
- 3) Remove repair drilling jig and finish drilling hole to correct depth indicated by stop collar on holesaw. Place steel tube (**T-4**) into slot and with a large screwdriver crack away from the resin and remove. (see **DIAGRAM 14**)

DIAGRAM 14

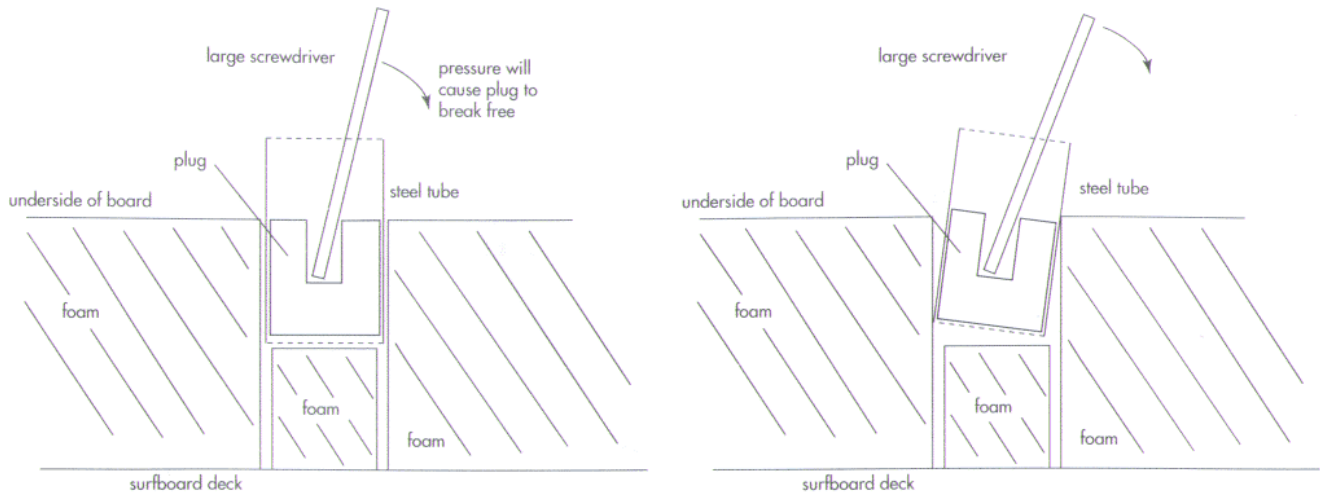

4) Use borer bit to remove a few more millimetres of resin so that the plug can fit in correctly. (see **DIAGRAM 15**)

DIAGRAM 15

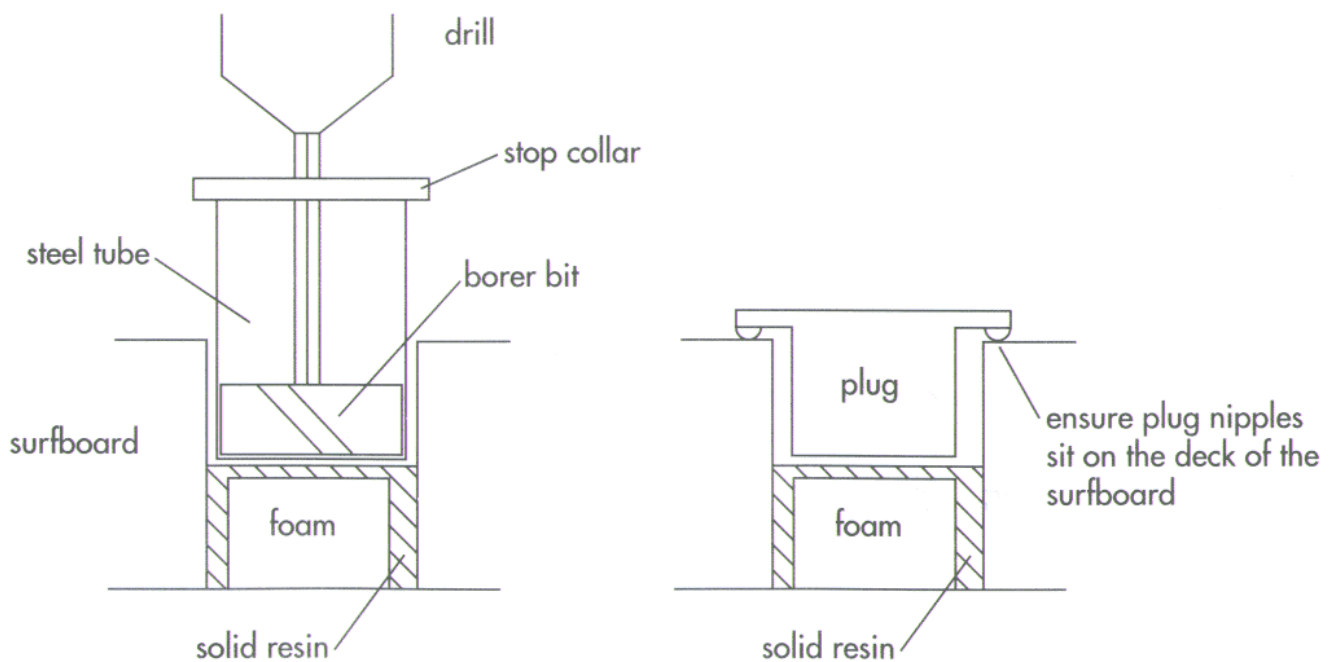

5) Install the new FCS plug in usual manner.

6) If the hole is very large you will have to refill cavity with Q-Cell or equivalent first. Then reinstall FCS plug.

INSTALLATION TOOLS

T-1

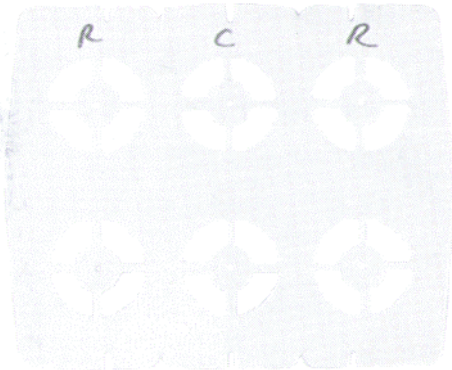

Marking Out Template

T-2



Centre Punch

T-3

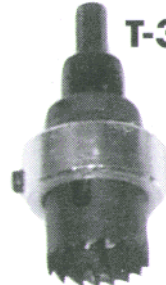

Holesaw

T-4



Steel Tube

T-7



Scribe Tool

T-5



Borer Bit

T-6



H-Pattern Tool

T-8a



Rail Dummy Jig

T-8b



Centre Dummy Jig



T-9

Putty

T-10

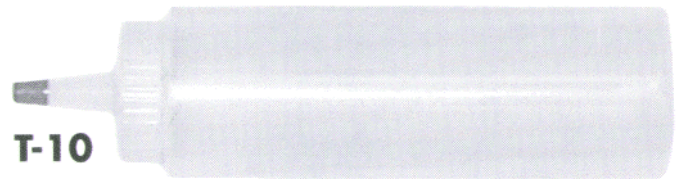

Squeeze Bottle

T-12



Allen Key

T-13



Measuring Cup

T-15



Spare Screw Pack

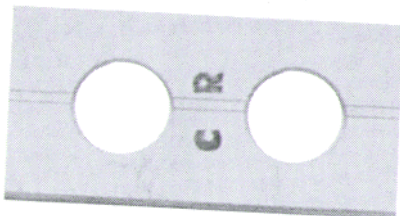

T-11

Repair Drilling Jig

T-14

Oversized Key